

BP-53V

3/16" AIR HYDRAULIC RIVETER

* with MANDREL COLLECT SYSTEM



SPECIFICATIONS

Model No.	BP-53V	
Riveting Capacity	All Material 3/32", 1/8", 2.4, 3.2, 4.0, 5/32", 3/16" 4.8 mm	
Traction Power	2,300 lbs	1,000kg
Hydraulic Stroke	5/8"	16mm
Operating Air Pressure	85-110 PSI	
Air Consumption	0.08Cuft.	2.2liter/rivet
Overall Length	11-5/16"	287 mm
Net Weight	4 lbs	1.8 kg
Min. Hose Size	3/8" I.D.	
Air Inlet	1/4" NPT	
Sound Pressure	79 DBA	
Vibration	<2.5M/S	

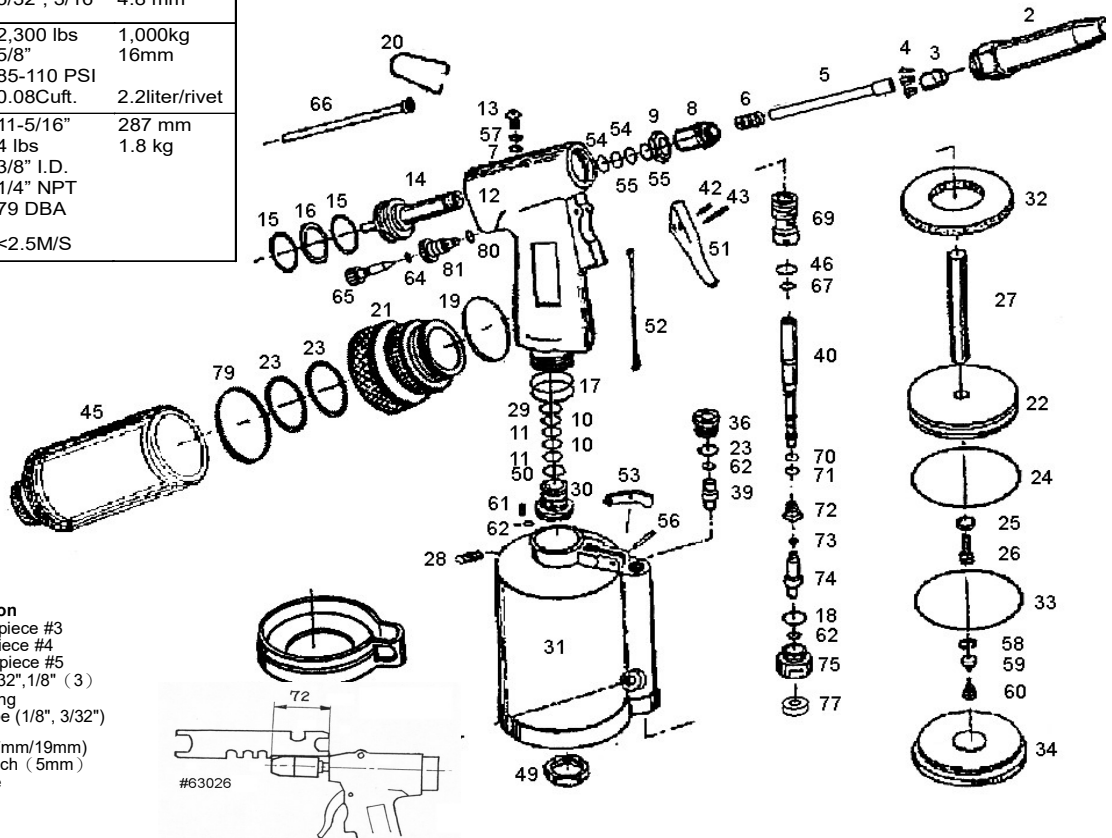

ACCESSORIES :

Index	P/N	Description
1A.	480017	3/32" Nosepiece #3
1B.	480018	1/8" Nosepiece #4
1C.	480532	5/32" Nosepiece #5
4.	A6618	Jaws for 3/32", 1/8" (3)
20	54059	Hanging Ring
66.	55080	Pusher Tube (1/8", 3/32")
*	63026	Wrench
*	17S19	Spanner (17mm/19mm)
*	54005	Hex. Wrench (5mm)
*	11790	Oil Syringe

B1501-HF22 '1/2013B2

Index No.	Part No.	Description	Index No.	Part No.	Description	Index No.	Part No.	Description
1D	480316	3/16" Nosepiece #6	27	02122	Plunger Rod	59	19312	Rubber Plate
2	55015	Head	28	55066	Screw	60	19313	Spring
3	55009	Jaw Housing	29	25022	O-Ring Seal	61	N2.5X10	Pin
4	10508	Jaw (3)	30	02157	Screw Plug	62	20413	O-Ring Seal (#23110)(3)
5	55007T	Pusher Tube	31	55001	Air Cylinder Body	64	55092	O-Ring Seal
6	540005	Spring	32	02130	Damping Ring	65	550322	Adjustable Screw
7	02197	O-Ring Seal	33	10431	O-Ring Seal	67	11560	O-Ring Seal
8	54006	Jaw Housing Coupler	34	54003	Air Cylinder Cap	69	55022	Valve Throttle
9	54004	Nut	36	55040	Bush Screw	70	R5X1.9	O-Ring Seal
10	11520	X-Ring Seal (2)	39	55038	Valve Plate	71	23111	O-Ring Seal
11	11558	O-Ring Washer (2)	40	55039	Valve Tube	72	10744	Spring
12	55002	Hydraulic Section	42	02168H	Pin	73	R1.9X1.2	O-Ring Seal
13	02171	Oil Plug	43	02169	Pin	74	55052A	Plug Pin
14	55051	Hydraulic Plunger	45	500610C	Mandrel Bottle Ass'y (short)	75	55050	Plug Screw
15	11501	O-Ring Seal (2)	46	10548	O-Ring Seal	76	#021470	Universal Joint Kit
16	11549	Washer	49	02121	Lock Nut	77	550521	Button Nut
17	02116	O-Ring Seal (2)	50	02170	O-Ring Seal	78	54070	Rubber Cushion
18	25203	O-Ring	51	02138	Trigger	79	P36X2	O-Ring
19	55019	O-Ring Seal	52	54033	Trigger Rod	80	R1.9X19	O-Ring Seal
21	55070	Screw Plug	53	02134	Trigger Lever	81	550321	Adjustable Bushing
22	02123	Piston Disc	54	11554	X-Ring Seal (2)	※ For pull small rivets 3/32"(2.4mm), 1/8"(3.2 mm) PLS Change (#5 / #55007T) Jaw Pusher & (#4 / 10508) Jaws AND replace (#66 / #55080) Pusher Tube & (#4 / #A6618) Jaws		
23	31413	O-Ring Seal (3)	55	11502	X-Ring Washer (2)			
24	02124	Air Piston Ring	56	02167	Pin			
25	76527	Spring Washer	57	400017A	Fill Washer			
26	10427	Piston Head Lock Screw	58	19314	Retaining Ring			